

PHYSICAL SPECIFICATION

Nominal Voltage Nominal Capacity (20HR)		6V 4.5Ah
Dimension	Length	70±1mm (2.76 inches)
	Width	47±1mm (1.85 inches)
	Container Height	100±1mm (3.94 inches)
	Total Height	106±1mm (4.17 inches)
Weight		Approx. 0.76Kg (1.68lbs)
Standard Terminal		Fasten Tab No.187E

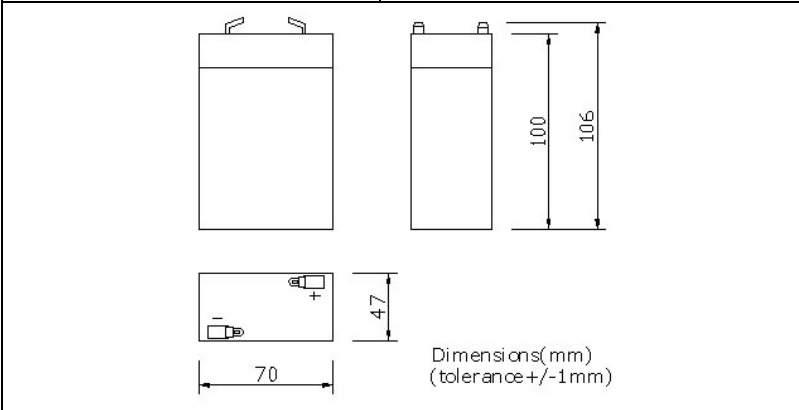

F1(Fasten Tab No.187E)
Standard Terminal

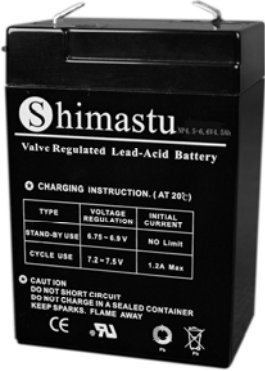
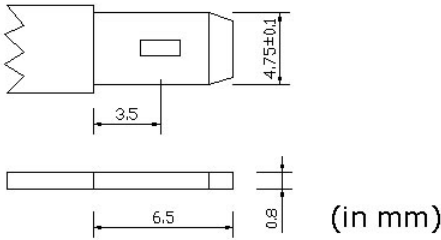

ELECTRICAL SPECIFICATION

Characteristics		
Capacity	20 hour rate (0.225A)	4.5Ah
	10 hour rate (0.405A)	4.2Ah
	5 hour rate (0.765A)	3.9Ah
	3 hour rate (1.125A)	3.4Ah
	1hour rate (2.7A)	2.7Ah
Capacity affected by temperature	40°C (104 °F)	102%
	25°C (77 °F)	100%
	0°C (32 °F)	85%
Internal Resistance		Full charged battery (25°C, 77 °F) 25mΩ
Constant Voltage Charge	Cycle	Initial Charging Current less than 1.35A Voltage 7.20~7.50V at 25°C (77 °F) Temperature Coefficient -15mV/°C
	Standby	No limit on Initial Charging Current Voltage 6.75~6.90V at 25°C (77 °F) Temperature Coefficient -10mV/°C

